

(12) **UK Patent Application** (19) **GB** (11) **2 381 019** (13) **A**

(43) Date of A Publication 23.04.2003

<p>(21) Application No 0219757.2</p> <p>(22) Date of Filing 23.08.2002</p> <p>(30) Priority Data (31) 09981916 (32) 18.10.2001 (33) US</p>	<p>(51) INT CL⁷ E21B 43/10 33/12 33/124 // E21B 43/12 43/14</p> <p>(52) UK CL (Edition V) E1F FKF FLA FLW FMU</p> <p>(56) Documents Cited GB 2370301 A GB 2344606 A GB 2343691 A EP 1152120 A US 20020148612 A1 US 20020066576 A1</p> <p>(58) Field of Search UK CL (Edition V) E1F FKA FKF FLA FLW FMU INT CL⁷ E21B 29/00 33/00 33/12 33/122 33/124 43/10 43/12 43/14 43/16 Other: Online: EPODOC, JAPIO, WPI, TXTEP, TXTGB, TXTUS, TXTWO.</p>
<p>(71) Applicant(s) Enventure Global Technology (Incorporated in USA - Delaware) 16200 A Park Row, Houston, Texas 77084, United States of America</p> <p>(72) Inventor(s) Robert Lance Cook Michael L Bullock</p> <p>(74) Agent and/or Address for Service Hazeltine Lake & Co Imperial House, 15-19 Kingsway, LONDON, WC2B 6UD, United Kingdom</p>	

(54) Abstract Title
Isolating sections of casings

(57) An opening 210 in a slotted casing 200 or a solid casing 200 caused by damaged or a perforation or fracturing operation is fluidically isolated from other sections of the casing by positioning an expandable tubular member 220 having a sealing member 225 within the casing 200 and expanding the tubular member by means of an expansion cone 235.

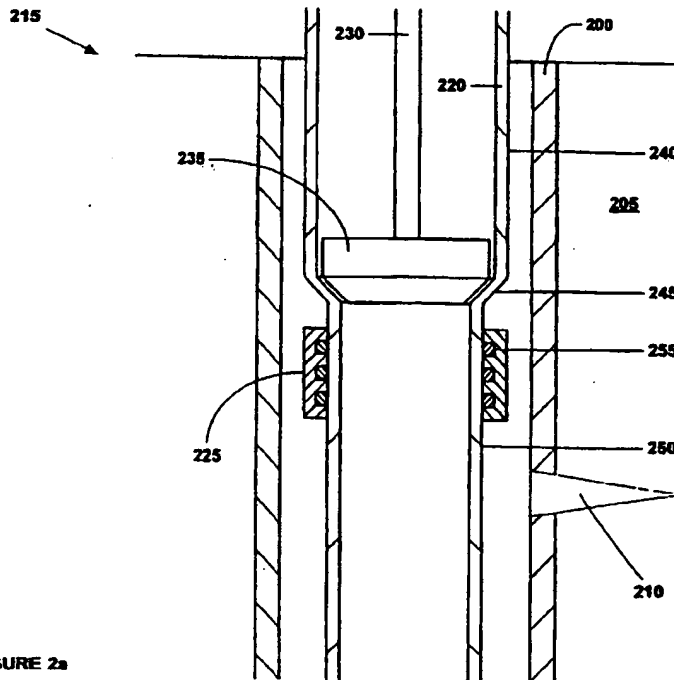

FIGURE 2a

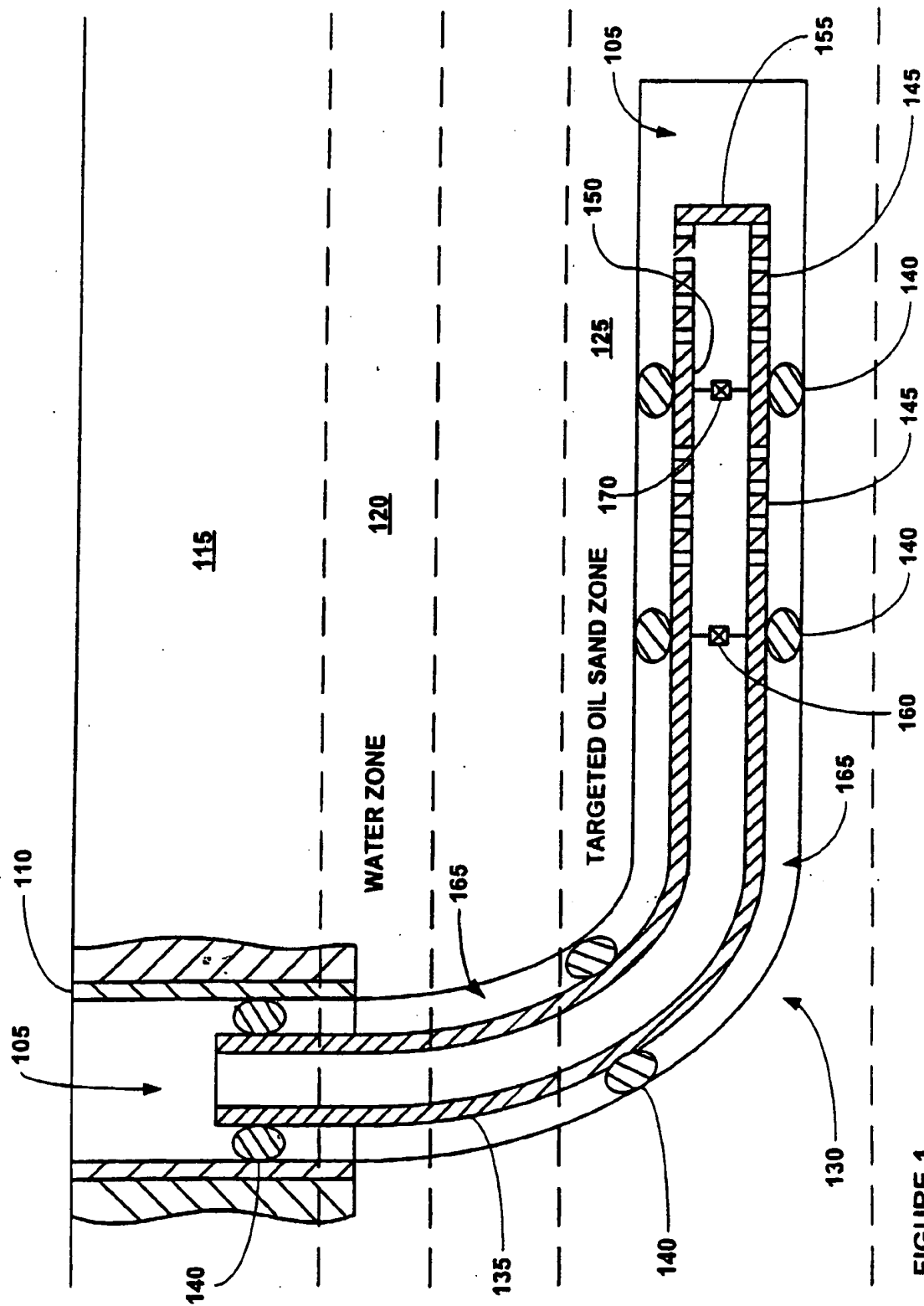

FIGURE 1

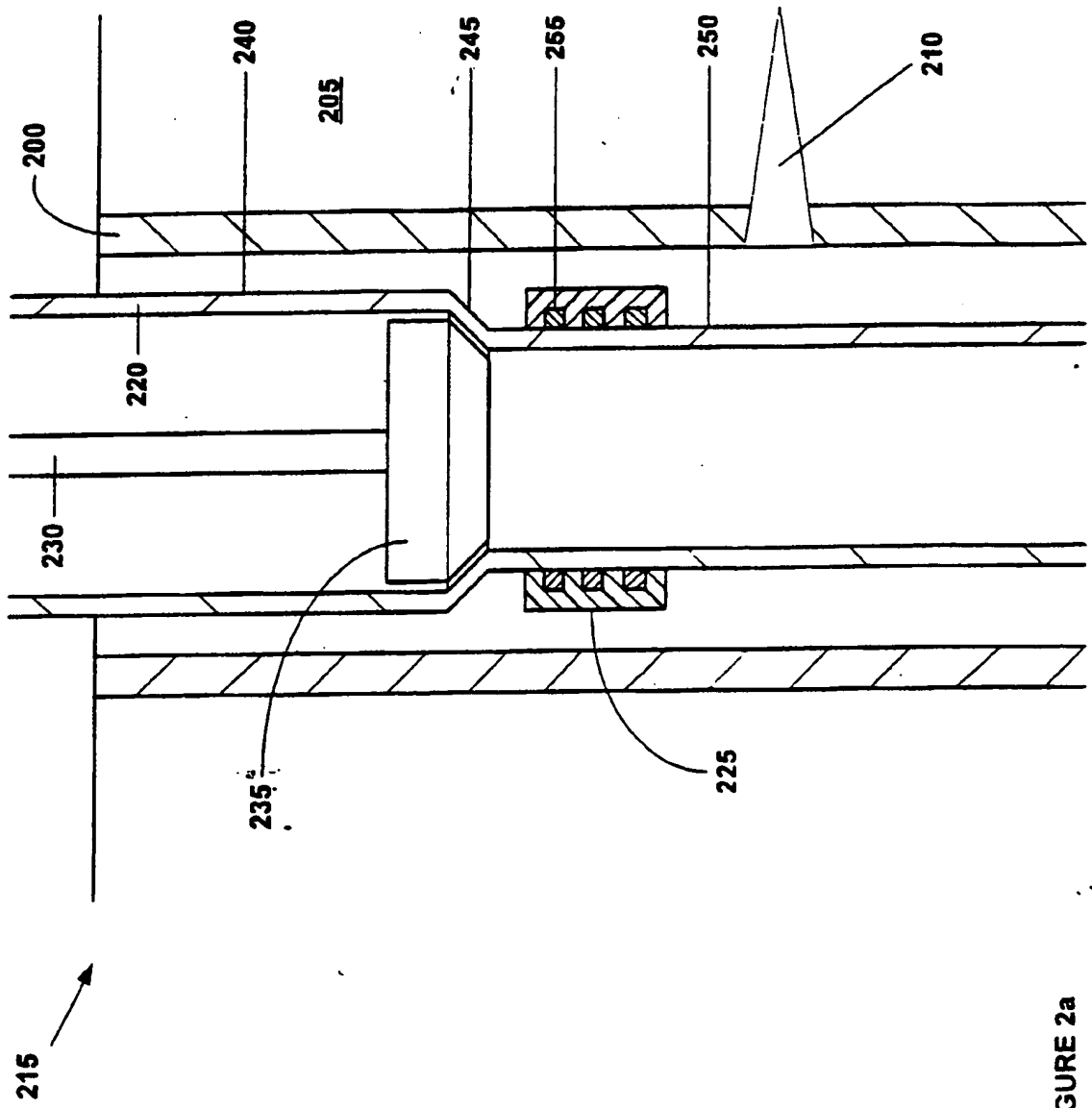

FIGURE 2a

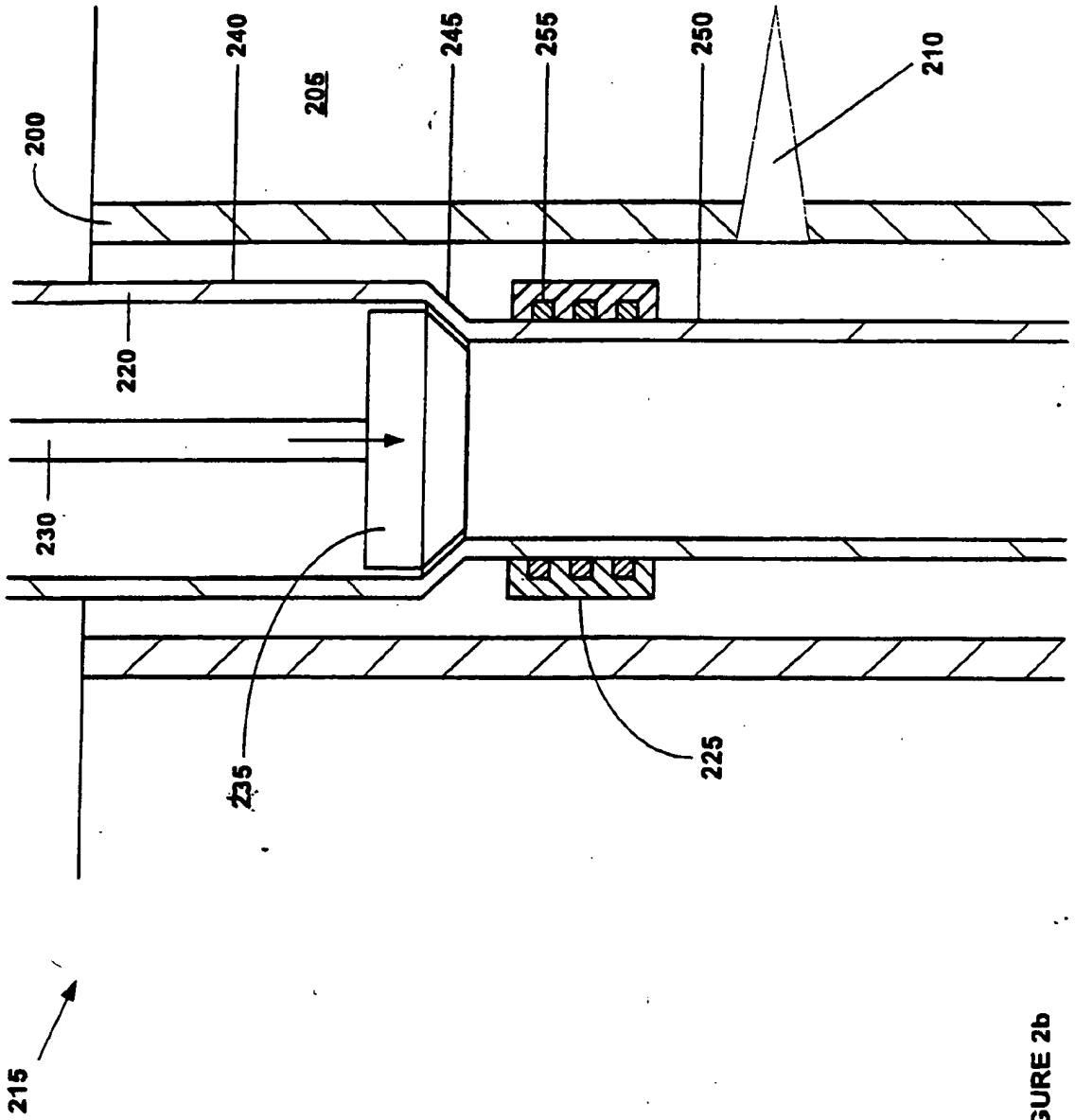

FIGURE 2b

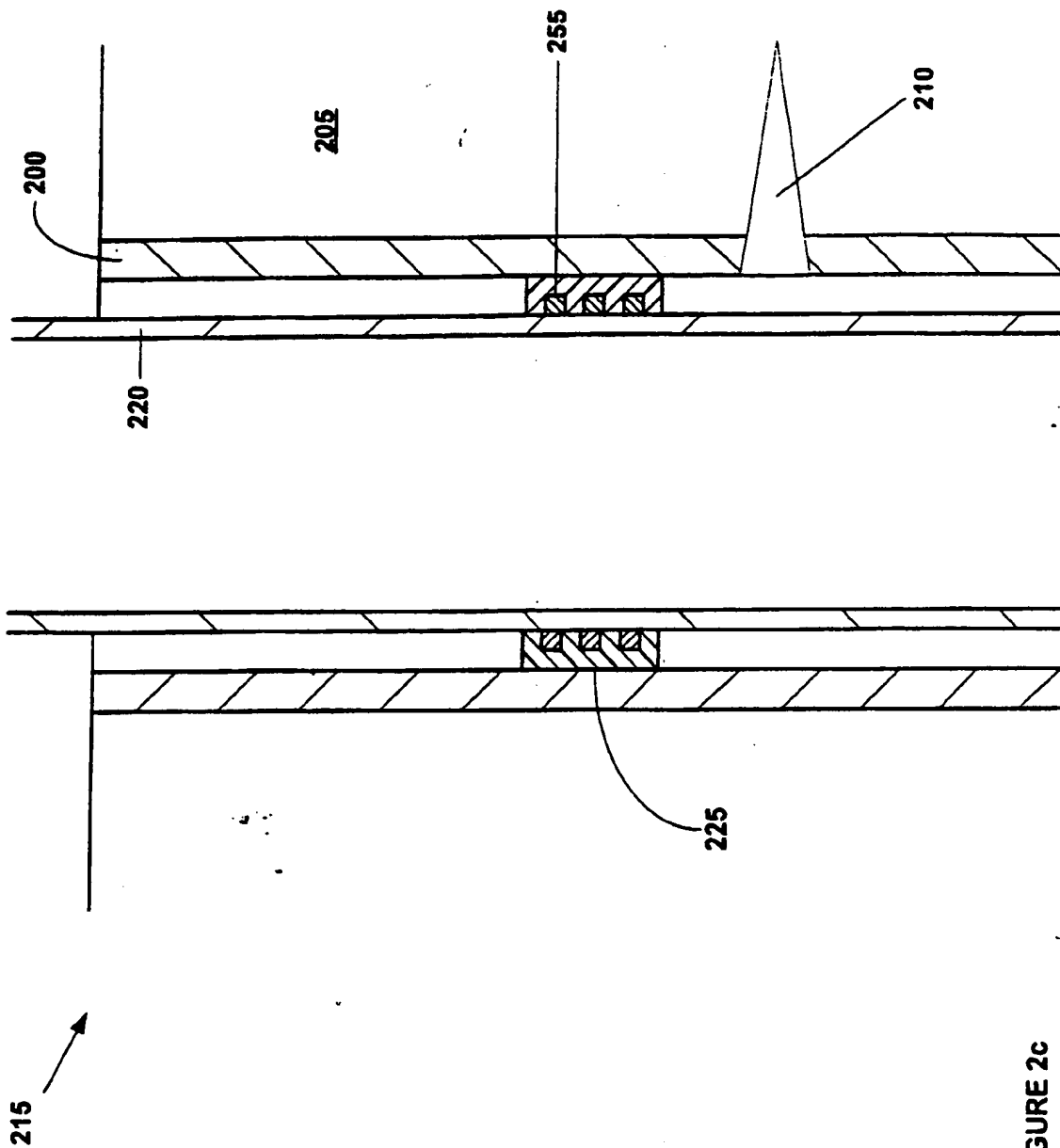

FIGURE 2c

2381019

EXPRESS MAIL LABEL NO.: <u>EL74:83485426</u>	DATE OF DEPOSIT: <u>OCTOBER 18, 2000</u>
I hereby certify that this paper and fee are being deposited with the United States Postal Service Express Mail Post Office to Addressee service under 37 CFR §1.10 on the date indicated above and is addressed to: Box PATENT APPLICATION, Assistant Commissioner for Patents, Washington, D.C. 20231.	
<u>Michelle Baxter</u>	<u>Michelle Baxter</u>
NAME OF PERSON MAILING PAPER AND FEE	SIGNATURE OF PERSON MAILING PAPER AND FEE

ISOLATION OF SUBTERRANEAN ZONES

Cross Reference To Related Applications

- 5 [0001] This application is a continuation-in-part of U.S. patent application serial number 09/440,338, attorney docket number 25791.9.02, filed on 11/15/1999, which claimed the benefit of the filing date of U.S. provisional patent application serial number 60/108,558, attorney docket number 25791.9, filed on 11/16/1998, the disclosures of which are incorporated herein by reference.
- 10 [0002] This application is related to the following: (1) U.S. patent application serial no. 09/454,139, attorney docket no. 25791.03.02, filed on 12/3/1999, (2) U.S. patent application serial no. 09/510,913, attorney docket no. 25791.7.02, filed on 2/23/2000, (3) U.S. patent application serial no. 09/502,350, attorney docket no. 25791.8.02, filed on 2/10/2000, (4) U.S. patent application serial no. 09/440,338, attorney docket no. 25791.9.02, filed on 11/15/1999, (5) U.S. patent application serial no. 09/523,460, attorney docket no. 25791.11.02, filed on 3/10/2000, (6) U.S. patent application serial no. 09/512,895, attorney docket no. 25791.12.02, filed on 2/24/2000, (7) U.S. patent application serial no. 09/511,941, attorney docket no. 25791.16.02, filed on 2/24/2000, (8) U.S. patent application serial no. 09/588,946, attorney docket no. 25791.17.02, filed on 6/7/2000, (9) U.S. patent application serial no. 09/559,122, attorney docket no. 25791.23.02, filed on 4/26/2000, (10) PCT patent application serial no. 25791.25.02, filed on 7/9/2000, (11) U.S. provisional patent application serial no. 60/162,671, attorney docket no. 25791.27, filed on 11/1/1999, (12) U.S. provisional patent application serial no.

60/154,047, attorney docket no. 25791.29, filed on 9/16/1999, (13) U.S. provisional patent application serial no. 60/159,082, attorney docket no. 25791.34, filed on 10/12/1999, (14) U.S. provisional patent application serial no. 60/159,039, attorney docket no. 25791.36, filed on 10/12/1999, (15) U.S.
5 provisional patent application serial no. 60/159,033, attorney docket no. 25791.37, filed on 10/12/1999, (16) U.S. provisional patent application serial no. 60/212,359, attorney docket no. 25791.38, filed on 6/19/2000, (17) U.S. provisional patent application serial no. 60/165,228, attorney docket no. 25791.39, filed on 11/12/1999, (18) U.S. provisional patent application serial no.
10 60/221,443, attorney docket no. 25791.45, filed on 7/28/2000, (19) U.S. provisional patent application serial no. 60/221,645, attorney docket no. 25791.46, filed on 7/28/2000, (20) U.S. provisional patent application serial no. 60/233,638, attorney docket no. 25791.47, filed on 9/18/2000, (21) U.S. provisional patent application serial no. 60/237,334, attorney docket no.
15 25791.48, filed on 10/2/2000, (22) U.S. provisional patent application serial no. 60/270,007, attorney docket no. 25791.50, filed on 2/20/2001; (23) U.S. provisional patent application serial no. 60/262,434, attorney docket no. 25791.51, filed on 1/17/2001; (24) U.S. provisional patent application serial no. 60/259,486, attorney docket no. 25791.52, filed on 1/3/2001; (25) U.S.
20 provisional patent application serial no. _____, attorney docket no. 25791.61, filed on 7/6/2001; (26) U.S. provisional patent application serial no. _____, attorney docket no. 25791.59, filed on 8/20/2001; (27) U.S. provisional patent application serial no. _____, attorney docket no. 25791.67, filed on 9/6/2001; (28) U.S. provisional patent application serial no.
25 _____, attorney docket no. 25791.67.02, filed on 9/10/2001; (29) U.S. provisional patent application serial no. 25791.60, filed on 10/3/2001; and (30) U.S. utility patent application serial no. _____, attorney docket no. 25791.69, filed on 10/3/2001, the disclosures of which are incorporated herein by ref renc .

Background of the Invention

[0003] This invention relates generally to oil and gas exploration, and in particular to isolating certain subterranean zones to facilitate oil and gas exploration.

5 [0004] During oil exploration, a wellbore typically traverses a number of zones within a subterranean formation. Some of these subterranean zones will produce oil and gas, while others will not. Further, it is often necessary to isolate subterranean zones from one another in order to facilitate the exploration for and production of oil and gas. Existing methods for isolating subterranean production zones in order to facilitate the exploration for and production of oil and gas are complex and expensive.

10 [0005] The present invention is directed to overcoming one or more of the limitations of the existing processes for isolating subterranean zones during oil and gas exploration.

Summary of the Invention

15 [0006] According to one aspect of the present invention, an apparatus is provided that includes one or more solid tubular members, each solid tubular member including one or more external seals, one or more slotted tubular members coupled to the solid tubular members, a shoe coupled to one of the slotted tubular members, and one or more packers positioned within one or more of the tubular members. Each packer includes a radially expanded tubular member and one or more sealing members coupled to the outer surface of the radially expanded tubular member.

20 [0007] According to another aspect of the present invention, an apparatus is provided that includes one or more primary solid tubulars, each primary solid tubular including one or more external annular seals, n slotted tubulars coupled to the primary solid tubulars, n-1 intermediate solid tubulars coupled to and interlaved among the slotted tubulars, each intermediate solid tubular including one or more external annular seals, a shoe coupled to one of the slotted tubulars, and one or more packers positioned within one or more of the tubulars.

25
30

Each packer includes a radially expanded tubular member and one or more sealing members coupled to the outer surface of the radially expanded tubular member.

5 **[0008]** According to another aspect of the present invention, a method of isolating a first subterranean zone from a second subterranean zone in a wellbore is provided that includes positioning one or more primary solid tubulars within the wellbore, the primary solid tubulars traversing the first subterranean zone, positioning one or more slotted tubulars within the wellbore, the slotted tubulars traversing the second subterranean zone, fluidically coupling the slotted tubulars and the solid tubulars, preventing the passage of fluids from the first subterranean zone to the second subterranean zone within the wellbore external to the solid and slotted tubulars and fluidically isolating one or more annular regions within one or more of the tubulars by the process of: positioning an expandable tubular member having one or more sealing members within the tubular, and radially expanding the expandable tubular member.

15 **[0009]** According to another aspect of the present invention, a method of extracting materials from a producing subterranean zone in a wellbore, at least a portion of the wellbore including a casing, is provided that includes positioning one or more primary solid tubulars within the wellbore, fluidically coupling the primary solid tubulars with the casing, positioning one or more slotted tubulars within the wellbore, the slotted tubulars traversing the producing subterranean zone, fluidically coupling the slotted tubulars with the solid tubulars, fluidically isolating the producing subterranean zone from at least one other subterranean zone within the wellbore, fluidically coupling at least one of the slotted tubulars with the producing subterranean zone, and fluidically isolating one or more annular regions within one or more of the tubulars by the process of: positioning an expandable tubular member having one or more sealing members within the tubular, and radially expanding the expandable tubular member.

20 **[0010]** According to another aspect of the present invention, an apparatus for fluidically isolating annular sections within a wellbore casing is provided that

includes an expandable tubular member adapted to be positioned within the wellbore casing, one or more sealing members coupled to an outside surface of the expandable tubular member, and an expansion cone movably coupled to the expandable tubular member adapted to radially expand the expandable tubular member.

5
[0011] According to another aspect of the present invention, a method of fluidically isolating annular sections within a wellbore casing is provided that includes positioning an expandable tubular member having one or more outer sealing members and an expansion cone within the wellbore casing, and axially displacing the expansion cone relative to the expandable tubular member.

10
[0012] According to another aspect of the present invention, a method of fluidically isolating an annular section of a wellbore casing including a collapsed section is provided that includes positioning an expandable tubular member having one or more outer sealing members and an expansion cone within the wellbore casing, moving at least a portion of the expandable tubular member through the collapsed section of the wellbore casing, and axially displacing the expansion cone relative to the expandable tubular member.

15
[0013] According to another aspect of the present invention, a packer for sealing an annular region between the packer and a wellbore casing is provided that includes a radially expanded tubular member, and one or more sealing members coupled to the outer surface of the radially expanded tubular member for sealing the annular region between the radially expanded tubular member and the wellbore casing.

20
[0014] According to another aspect of the present invention, a method of operating a packer including an expandable tubular member and an annular sealing member coupled to the exterior of the expandable tubular member has been provided that includes positioning the packer within a subterranean borehole, and radially expanding the expandable tubular member using an expansion cone.

Brief Description of the Drawings

[0015] FIG. 1 is a fragmentary cross-sectional view illustrating the isolation of subterranean zones.

5 [0016] FIG. 2a is a fragmentary cross-sectional illustration of an embodiment of an apparatus for fluidically isolating annular regions within a wellbore casing.

[0017] FIG. 2b is a fragmentary cross-sectional illustration of the apparatus of FIG. 2a after initiating the axial displacement of the expansion cone.

10 [0018] FIG. 2c is a fragmentary cross-sectional illustration of the apparatus of FIG. 2b after completion of the radial expansion process.

Detailed Description of the Illustrative Embodiments

[0019] An apparatus and method for isolating one or more subterranean zones from one or more other subterranean zones is provided. The apparatus and method permits a producing zone to be isolated from a nonproducing zone using a combination of solid and slotted tubulars. In the production mode, the teachings of the present disclosure may be used in combination with conventional, well known, production completion equipment and methods using a series of packers, solid tubing, perforated tubing, and sliding sleeves, which will be inserted into the disclosed apparatus to permit the commingling and/or isolation of the subterranean zones from each other.

20 [0020] An apparatus and method for providing a packer for use in isolating one or more subterranean zones from one or more subterranean zones is also provided. The apparatus and method permit a packer to be provided by radially expanding a tubular member including one or more outer sealing members into engagement with a preexisting tubular structure.

25 [0021] Referring to Fig. 1, a wellbore 105 including a casing 110 is positioned in a subterranean formation 115. The subterranean formation 115 includes a number of productive and non-productive zones, including a water

zone 120 and a targeted oil sand zone 125. During exploration of the subterranean formation 115, the wellbore 105 may be extended in a well known manner to traverse the various productive and non-productive zones, including the water zone 120 and the targeted oil sand zone 125.

5 [0022] In a preferred embodiment, in order to fluidically isolate the water zone 120 from the targeted oil sand zone 125, an apparatus 130 is provided that includes one or more sections of solid casing 135, one or more external seals 140, one or more sections of slotted casing 145, one or more intermediate sections of solid casing 150, and a solid shoe 155.

10 [0023] The solid casing 135 may provide a fluid conduit that transmits fluids and other materials from one end of the solid casing 135 to the other end of the solid casing 135. The solid casing 135 may comprise any number of conventional commercially available sections of solid tubular casing such as, for example, oilfield tubulars fabricated from chromium steel or fiberglass. In a preferred embodiment, the solid casing 135 comprises oilfield tubulars available
15 from various foreign and domestic steel mills.

[0024] The solid casing 135 is preferably coupled to the casing 110. The solid casing 135 may be coupled to the casing 110 using any number of conventional commercially available processes such as, for example, welding,
20 slotted and expandable connectors, or expandable solid connectors. In a preferred embodiment, the solid casing 135 is coupled to the casing 110 by using expandable solid connectors. The solid casing 135 may comprise a plurality of such solid casing 135.

[0025] The solid casing 135 is preferably coupled to one more of the
25 slotted casings 145. The solid casing 135 may be coupled to the slotted casing 145 using any number of conventional commercially available processes such as, for example, welding, or slotted and expandable connectors. In a preferred embodiment, the solid casing 135 is coupled to the slotted casing 145 by expandable solid connectors.

[0026] In a preferred embodiment, the casing 135 includes one more valve members 160 for controlling the flow of fluids and other materials within the interior region of the casing 135. In an alternative embodiment, during the production mode of operation, an internal tubular string with various
5 arrangements of packers, perforated tubing, sliding sleeves, and valves may be employed within the apparatus to provide various options for commingling and isolating subterranean zones from each other while providing a fluid path to the surface.

[0027] In a particularly preferred embodiment, the casing 135 is placed
10 into the wellbore 105 by expanding the casing 135 in the radial direction into intimate contact with the interior walls of the wellbore 105. The casing 135 may be expanded in the radial direction using any number of conventional commercially available methods. In a preferred embodiment, the casing 135 is expanded in the radial direction using one or more of the apparatus and methods
15 disclosed in the following: (1) U.S. patent application serial no. 09/454,139, attorney docket no. 25791.03.02, filed on 12/3/1999, (2) U.S. patent application serial no. 09/510,913, attorney docket no. 25791.7.02, filed on 2/23/2000, (3) U.S. patent application serial no. 09/502,350, attorney docket no. 25791.8.02, filed on 2/10/2000, (4) U.S. patent application serial no. 09/440,338, attorney
20 docket no. 25791.9.02, filed on 11/15/1999, (5) U.S. patent application serial no. 09/523,460, attorney docket no. 25791.11.02, filed on 3/10/2000, (6) U.S. patent application serial no. 09/512,895, attorney docket no. 25791.12.02, filed on 2/24/2000, (7) U.S. patent application serial no. 09/511,941, attorney docket no. 25791.16.02, filed on 2/24/2000, (8) U.S. patent application serial no.
25 09/588,946, attorney docket no. 25791.17.02, filed on 6/7/2000, (9) U.S. patent application serial no. 09/559,122, attorney docket no. 25791.23.02, filed on 4/26/2000, (10) PCT patent application serial no. PCT/US00/18635, attorney docket no. 25791.25.02, filed on 7/9/2000, (11) U.S. provisional patent application serial no. 60/162,671, attorney docket no. 25791.27, filed on
30 11/1/1999, (12) U.S. provisional patent application serial no. 60/154,047,

attorney docket no. 25791.29, filed on 9/16/1999, (13) U.S. provisional patent application serial no. 60/159,082, attorney docket no. 25791.34, filed on 10/12/1999, (14) U.S. provisional patent application serial no. 60/159,039, attorney docket no. 25791.36, filed on 10/12/1999, (15) U.S. provisional patent application serial no. 60/159,033, attorney docket no. 25791.37, filed on 10/12/1999, (16) U.S. provisional patent application serial no. 60/212,359, attorney docket no. 25791.38, filed on 6/19/2000, (17) U.S. provisional patent application serial no. 60/165,228, attorney docket no. 25791.39, filed on 11/12/1999, (18) U.S. provisional patent application serial no. 60/221,443, attorney docket no. 25791.45, filed on 7/28/2000, (19) U.S. provisional patent application serial no. 60/221,645, attorney docket no. 25791.46, filed on 7/28/2000, (20) U.S. provisional patent application serial no. 60/233,638, attorney docket no. 25791.47, filed on 9/18/2000, (21) U.S. provisional patent application serial no. 60/237,334, attorney docket no. 25791.48, filed on 10/2/2000, (22) U.S. provisional patent application serial no. 60/270,007, attorney docket no. 25791.50, filed on 2/20/2001; (23) U.S. provisional patent application serial no. 60/262,434, attorney docket no. 25791.51, filed on 1/17/2001; (24) U.S. provisional patent application serial no. 60/259,486, attorney docket no. 25791.52, filed on 1/3/2001; (25) U.S. provisional patent application serial no. _____, attorney docket no. 25791.61, filed on 7/6/2001; (26) U.S. provisional patent application serial no. _____, attorney docket no. 25791.59, filed on 8/20/2001; (27) U.S. provisional patent application serial no. _____, attorney docket no. 25791.67, filed on 9/6/2001; and (28) U.S. provisional patent application serial no. _____, attorney docket no. 25791.67.02, filed on 9/10/2001, the disclosures of which are incorporated herein by reference.

[0028] The seals 140 prevent the passage of fluids and other materials within the annular region 165 between the solid casings 135 and 150 and the wellbore 105. The seals 140 may comprise any number of conventional commercially available sealing materials suitable for sealing a casing in a

wellbore such as, for example, lead, rubber or epoxy. In a preferred embodiment, the seals 140 comprise Stratalok epoxy material available from Halliburton Energy Services.

5 [0029] The slotted casing 145 permits fluids and other materials to pass into and out of the interior of the slotted casing 145 from and to the annular region 165. In this manner, oil and gas may be produced from a producing subterranean zone within a subterranean formation. The slotted casing 145 may comprise any number of conventional commercially available sections of slotted tubular casing. In a preferred embodiment, the slotted casing 145 comprises
10 expandable slotted tubular casing available from Petrolite in Aberdeen, Scotland. In a particularly preferred embodiment, the slotted casing 145 comprises expandable slotted sandscreen tubular casing available from Petrolite in Aberdeen, Scotland.

15 [0030] The slotted casing 145 is preferably coupled to one or more solid casing 135. The slotted casing 145 may be coupled to the solid casing 135 using any number of conventional commercially available processes such as, for example, welding, or slotted or solid expandable connectors. In a preferred embodiment, the slotted casing 145 is coupled to the solid casing 135 by expandable solid connectors.

20 [0031] The slotted casing 145 is preferably coupled to one or more intermediate solid casings 150. The slotted casing 145 may be coupled to the intermediate solid casing 150 using any number of conventional commercially available processes such as, for example, welding or expandable solid or slotted connectors. In a preferred embodiment, the slotted casing 145 is coupled to the
25 intermediate solid casing 150 by expandable solid connectors.

[0032] The last slotted casing 145 is preferably coupled to the shoe 155. The last slotted casing 145 may be coupled to the shoe 155 using any number of conventional commercially available processes such as, for example, welding or expandable solid or slotted connectors. In a preferred embodiment, the last
30 slotted casing 145 is coupled to the shoe 155 by an expandable solid connector.

[0033] In an alternative embodiment, the shoe 155 is coupled directly to the last one of the intermediate solid casings 150.

[0034] In a preferred embodiment, the slotted casings 145 are positioned within the wellbore 105 by expanding the slotted casings 145 in a radial direction into intimate contact with the interior walls of the wellbore 105. The slotted casings 145 may be expanded in a radial direction using any number of conventional commercially available processes.

[0035] The intermediate solid casing 150 permits fluids and other materials to pass between adjacent slotted casings 145. The intermediate solid casing 150 may comprise any number of conventional commercially available sections of solid tubular casing such as, for example, oilfield tubulars fabricated from chromium steel or fiberglass. In a preferred embodiment, the intermediate solid casing 150 comprises oilfield tubulars available from foreign and domestic steel mills.

[0036] The intermediate solid casing 150 is preferably coupled to one or more sections of the slotted casing 145. The intermediate solid casing 150 may be coupled to the slotted casing 145 using any number of conventional commercially available processes such as, for example, welding, or solid or slotted expandable connectors. In a preferred embodiment, the intermediate solid casing 150 is coupled to the slotted casing 145 by expandable solid connectors. The intermediate solid casing 150 may comprise a plurality of such intermediate solid casing 150.

[0037] In a preferred embodiment, each intermediate solid casing 150 includes one or more valve members 170 for controlling the flow of fluids and other materials within the interior region of the intermediate casing 150. In an alternative embodiment, as will be recognized by persons having ordinary skill in the art and the benefit of the present disclosure, during the production mode of operation, an internal tubular string with various arrangements of packers, perforated tubing, sliding sleeves, and valves may be employed within the

apparatus to provide various options for commingling and isolating subterranean zones from each other while providing a fluid path to the surface.

5 [0038] In a particularly preferred embodiment, the intermediate casing 150 is placed into the wellbore 105 by expanding the intermediate casing 150 in the radial direction into intimate contact with the interior walls of the wellbore 105. The intermediate casing 150 may be expanded in the radial direction using any number of conventional commercially available methods.

10 [0039] In an alternative embodiment, one or more of the intermediate solid casings 150 may be omitted. In an alternative preferred embodiment, one or more of the slotted casings 145 are provided with one or more seals 140.

15 [0040] The shoe 155 provides a support member for the apparatus 130. In this manner, various production and exploration tools may be supported by the shoe 155. The shoe 155 may comprise any number of conventional commercially available shoes suitable for use in a wellbore such as, for example, cement filled shoe, or an aluminum or composite shoe. In a preferred embodiment, the shoe 155 comprises an aluminum shoe available from Halliburton. In a preferred embodiment, the shoe 155 is selected to provide sufficient strength in compression and tension to permit the use of high capacity production and exploration tools.

20 [0041] In a particularly preferred embodiment, the apparatus 130 includes a plurality of solid casings 135, a plurality of seals 140, a plurality of slotted casings 145, a plurality of intermediate solid casings 150, and a shoe 155. More generally, the apparatus 130 may comprise one or more solid casings 135, each with one or more valve members 160, n slotted casings 145, n-1 intermediate solid casings 150, each with one or more valve members 170, and a shoe 155.

25 [0042] During operation of the apparatus 130, oil and gas may be controllably produced from the targeted oil sand zone 125 using the slotted casings 145. The oil and gas may then be transported to a surface location using the solid casing 135. The use of intermediate solid casings 150 with valve members 170 permits isolated sections of the zone 125 to be selectively isolated

30

for production. The seals 140 permit the zone 125 to be fluidically isolated from the zone 120. The seals 140 further permits isolated sections of the zone 125 to be fluidically isolated from each other. In this manner, the apparatus 130 permits unwanted and/or non-productive subterranean zones to be fluidically isolated.

5 [0043] In an alternative embodiment, as will be recognized by persons having ordinary skill in the art and also having the benefit of the present disclosure, during the production mode of operation, an internal tubular string with various arrangements of packers, perforated tubing, sliding sleeves, and valves may be employed within the apparatus to provide various options for
10 commingling and isolating subterranean zones from each other while providing a fluid path to the surface.

[0044] Referring to FIGS. 2a, 2b, and 2c, a preferred embodiment of a method and apparatus for fluidically isolating a section of a wellbore casing will be described. Referring to Fig. 2a, a wellbore casing 200 is positioned within a
15 subterranean formation 205. The wellbore casing 200 may be positioned in any orientation from the vertical direction to the horizontal direction. The wellbore casing 200 further includes one or more openings 210 that may have been, for example, the result of: (1) unintentional damage to the wellbore casing 200, (2) a prior perforation or fracturing operation performed upon the surrounding
20 subterranean formation 205, or (3) a slotted section of the wellbore casing 200. As will be recognized by persons having ordinary skill in the art, the openings 210 can affect the subsequent operation and use of the wellbore casing 200 unless they are fluidically isolated from other regions within the wellbore casing 200. In a preferred embodiment, an apparatus 215 is utilized to fluidically isolate
25 openings 110 within the wellbore casing 100.

[0045] The apparatus 215 preferably includes an expandable tubular member 220, one or more sealing members 225, a support member 230, and an expansion con 235.

[0046] The expandable tubular member 220 is preferably adapted to be
30 supported from above by conventional support members. The expandabl

tubular member 220 is further coupled to the sealing members 225 and movably coupled to the expansion cone 235. The expandable tubular member 220 preferably includes an upper section 240, an intermediate section 245, and a lower section 250. In a preferred embodiment, the upper and intermediate sections, 240 and 245, are adapted to mate with the expansion cone 235. In a preferred embodiment, the wall thickness of the lower section 250 is less than the wall thickness of the upper and intermediate sections, 240 and 245.

5 [0047] In a preferred embodiment, the expandable tubular member 220 is provided as disclosed in one or more of the following: (1) U.S. patent application serial no. 09/454,139, attorney docket no. 25791.03.02, filed on 12/3/1999, (2) 10 U.S. patent application serial no. 09/510,913, attorney docket no. 25791.7.02, filed on 2/23/2000, (3) U.S. patent application serial no. 09/502,350, attorney docket no. 25791.8.02, filed on 2/10/2000, (4) U.S. patent application serial no. 09/440,338, attorney docket no. 25791.9.02, filed on 11/15/1999, (5) U.S. patent 15 application serial no. 09/523,460, attorney docket no. 25791.11.02, filed on 3/10/2000, (6) U.S. patent application serial no. 09/512,895, attorney docket no. 25791.12.02, filed on 2/24/2000, (7) U.S. patent application serial no. 09/511,941, attorney docket no. 25791.16.02, filed on 2/24/2000, (8) U.S. patent application serial no. 09/588,946, attorney docket no. 25791.17.02, filed on 20 6/7/2000, (9) U.S. patent application serial no. 09/559,122, attorney docket no. 25791.23.02, filed on 4/26/2000, (10) PCT patent application serial no. PCT/US00/18635, attorney docket no. 25791.25.02, filed on 7/9/2000, (11) U.S. provisional patent application serial no. 60/162,671, attorney docket no. 25791.27, filed on 11/1/1999, (12) U.S. provisional patent application serial no. 25 60/154,047, attorney docket no. 25791.29, filed on 9/16/1999, (13) U.S. provisional patent application serial no. 60/159,082, attorney docket no. 25791.34, filed on 10/12/1999, (14) U.S. provisional patent application serial no. 60/159,039, attorney docket no. 25791.36, filed on 10/12/1999, (15) U.S. provisional patent application serial no. 60/159,033, attorney docket no. 30 25791.37, filed on 10/12/1999, (16) U.S. provisional patent application serial no.

60/212,359, attorney docket no. 25791.38, filed on 6/19/2000, (17) U.S. provisional patent application serial no. 60/165,228, attorney docket no. 25791.39, filed on 11/12/1999, (18) U.S. provisional patent application serial no. 60/221,443, attorney docket no. 25791.45, filed on 7/28/2000, (19) U.S. provisional patent application serial no. 60/221,645, attorney docket no. 25791.46, filed on 7/28/2000, (20) U.S. provisional patent application serial no. 60/233,638, attorney docket no. 25791.47, filed on 9/18/2000, (21) U.S. provisional patent application serial no. 60/237,334, attorney docket no. 25791.48, filed on 10/2/2000, (22) U.S. provisional patent application serial no. 60/270,007, attorney docket no. 25791.50, filed on 2/20/2001; (23) U.S. provisional patent application serial no. 60/262,434, attorney docket no. 25791.51, filed on 1/17/2001; (24) U.S. provisional patent application serial no. 60/259,486, attorney docket no. 25791.52, filed on 1/3/2001; (25) U.S. provisional patent application serial no. _____, attorney docket no. 25791.61, filed on 7/6/2001; (26) U.S. provisional patent application serial no. _____, attorney docket no. 25791.59, filed on 8/20/2001; (27) U.S. provisional patent application serial no. _____, attorney docket no. 25791.67, filed on 9/6/2001; and (28) U.S. provisional patent application serial no. _____, attorney docket no. 25791.67.02, filed on 9/10/2001, the disclosures of which are incorporated herein by reference.

[0048] In several alternative embodiments, the expandable tubular member 220 includes one or more slotted portions to permit the passage of fluidic materials from the interior to the exterior of the expandable tubular member 220. In this manner, production fluids may be conveyed to and from the annular region between the expandable tubular member 220 and the wellbore casing 200.

[0049] The sealing members 225 are coupled to the outer surface of the expandable tubular member 220. The sealing members 225 are preferably adapted to fluidically seal the interface between the radially expanded tubular member 220 and the wellbore casing 200. In this manner, the opening 210 is

fluidically isolated from other sections of the wellbore casing. In a preferred embodiment, the apparatus 215 includes a plurality of sealing members 225, positioned above and below the position of the opening 210 in order to surround and completely fluidically isolate the opening 210. The sealing members 225 may be any number of conventional sealing members. In a preferred embodiment, the sealing members 225 include one or more reinforcing inner rings 255.

5 [0050] The support member 230 is preferably adapted to be support from above by conventional support members. The support member 230 is further coupled to the expansion cone 235.

10 [0051] The expansion cone 235 is coupled to the support member 230. The expansion cone 235 is further movably coupled to the expandable tubular member 220. The expansion cone 235 is preferably adapted to radially expand the expandable tubular member 220 when axially displaced relative to the expandable tubular member 220.

15 [0052] The expansion cone 235 is preferably provided as disclosed in one or more of the following: (1) U.S. patent application serial no. 09/454,139, attorney docket no. 25791.03.02, filed on 12/3/1999, (2) U.S. patent application serial no. 09/510,913, attorney docket no. 25791.7.02, filed on 2/23/2000, (3) U.S. patent application serial no. 09/502,350, attorney docket no. 25791.8.02, filed on 2/10/2000, (4) U.S. patent application serial no. 09/440,338, attorney docket no. 25791.9.02, filed on 11/15/1999, (5) U.S. patent application serial no. 09/523,460, attorney docket no. 25791.11.02, filed on 3/10/2000, (6) U.S. patent application serial no. 09/512,895, attorney docket no. 25791.12.02, filed on 2/24/2000, (7) U.S. patent application serial no. 09/511,941, attorney docket no. 25791.16.02, filed on 2/24/2000, (8) U.S. patent application serial no. 09/588,946, attorney docket no. 25791.17.02, filed on 6/7/2000, (9) U.S. patent application serial no. 09/559,122, attorney docket no. 25791.23.02, filed on 4/26/2000, (10) PCT patent application serial no. PCT/US00/18635, attorney docket no. 25791.25.02, filed on 7/9/2000, (11) U.S. provisional patent application serial no. 60/162,671, attorney docket no. 25791.27, filed on

20
25
30

11/1/1999, (12) U.S. provisional patent application serial no. 60/154,047, attorney docket no. 25791.29, filed on 9/16/1999, (13) U.S. provisional patent application serial no. 60/159,082, attorney docket no. 25791.34, filed on 10/12/1999, (14) U.S. provisional patent application serial no. 60/159,039, attorney docket no. 25791.36, filed on 10/12/1999, (15) U.S. provisional patent application serial no. 60/159,033, attorney docket no. 25791.37, filed on 10/12/1999, (16) U.S. provisional patent application serial no. 60/212,359, attorney docket no. 25791.38, filed on 6/19/2000, (17) U.S. provisional patent application serial no. 60/165,228, attorney docket no. 25791.39, filed on 11/12/1999, (18) U.S. provisional patent application serial no. 60/221,443, attorney docket no. 25791.45, filed on 7/28/2000, (19) U.S. provisional patent application serial no. 60/221,645, attorney docket no. 25791.46, filed on 7/28/2000, (20) U.S. provisional patent application serial no. 60/233,638, attorney docket no. 25791.47, filed on 9/18/2000, (21) U.S. provisional patent application serial no. 60/237,334, attorney docket no. 25791.48, filed on 10/2/2000, (22) U.S. provisional patent application serial no. 60/270,007, attorney docket no. 25791.50, filed on 2/20/2001; (23) U.S. provisional patent application serial no. 60/262,434, attorney docket no. 25791.51, filed on 1/17/2001; (24) U.S. provisional patent application serial no. 60/259,486, attorney docket no. 25791.52, filed on 1/3/2001; (25) U.S. provisional patent application serial no. _____, attorney docket no. 25791.61, filed on 7/6/2001; (26) U.S. provisional patent application serial no. _____, attorney docket no. 25791.59, filed on 8/20/2001; (27) U.S. provisional patent application serial no. _____, attorney docket no. 25791.67, filed on 9/6/2001; and (28) U.S. provisional patent application serial no. _____, attorney docket no. 25791.67.02, filed on 9/10/2001, the disclosures of which are incorporated herein by reference.

[0053] As illustrated in FIG. 2a, the apparatus 215 is preferably positioned within the wellbore casing 200 at a predetermined position relative to the opening 210. During placement of the apparatus 215, the expandable tubular member

220 and the support member 230 are preferably support and positioned using conventional support and positioning equipment.

[0054] As illustrated in FIG. 2b, in a preferred embodiment, the expansion cone 235 is then axially displaced relative to the expandable tubular member 220. In a preferred embodiment, the axial displacement of the expansion cone 235 radially expands the expandable tubular member 220. In a preferred embodiment, the expandable tubular member 220 is radially expanded by about 8 to 40 %.

[0055] As illustrated in FIG. 2c, after completing the radial expansion of the expandable tubular member 220, the annular region between the radially expanded tubular member 220 and the wellbore casing 200 is fluidically sealed by the sealing members 225. In this manner, the openings 210 are fluidically isolated from other sections of the wellbore casing 200.

[0056] In several alternative embodiments, the expandable tubular member 220 is radially expanded using one or more of the apparatus and methods disclosed in the following: (1) U.S. patent application serial no. 09/454,139, attorney docket no. 25791.03.02, filed on 12/3/1999, (2) U.S. patent application serial no. 09/510,913, attorney docket no. 25791.7.02, filed on 2/23/2000, (3) U.S. patent application serial no. 09/502,350, attorney docket no. 25791.8.02, filed on 2/10/2000, (4) U.S. patent application serial no. 09/440,338, attorney docket no. 25791.9.02, filed on 11/15/1999, (5) U.S. patent application serial no. 09/523,460, attorney docket no. 25791.11.02, filed on 3/10/2000, (6) U.S. patent application serial no. 09/512,895, attorney docket no. 25791.12.02, filed on 2/24/2000, (7) U.S. patent application serial no. 09/511,941, attorney docket no. 25791.16.02, filed on 2/24/2000, (8) U.S. patent application serial no. 09/588,946, attorney docket no. 25791.17.02, filed on 6/7/2000, (9) U.S. patent application serial no. 09/559,122, attorney docket no. 25791.23.02, filed on 4/26/2000, (10) PCT patent application serial no. PCT/US00/18635, attorney docket no. 25791.25.02, filed on 7/9/2000, (11) U.S. provisional patent application serial no. 60/162,671, attorney docket no. 25791.27, filed on

11/1/1999, (12) U.S. provisional patent application serial no. 60/154,047, attorney docket no. 25791.29, filed on 9/16/1999, (13) U.S. provisional patent application serial no. 60/159,082, attorney docket no. 25791.34, filed on 10/12/1999, (14) U.S. provisional patent application serial no. 60/159,039, attorney docket no. 25791.36, filed on 10/12/1999, (15) U.S. provisional patent application serial no. 60/159,033, attorney docket no. 25791.37, filed on 10/12/1999, (16) U.S. provisional patent application serial no. 60/212,359, attorney docket no. 25791.38, filed on 6/19/2000, (17) U.S. provisional patent application serial no. 60/165,228, attorney docket no. 25791.39, filed on 11/12/1999, (18) U.S. provisional patent application serial no. 60/221,443, attorney docket no. 25791.45, filed on 7/28/2000, (19) U.S. provisional patent application serial no. 60/221,645, attorney docket no. 25791.46, filed on 7/28/2000, (20) U.S. provisional patent application serial no. 60/233,638, attorney docket no. 25791.47, filed on 9/18/2000, (21) U.S. provisional patent application serial no. 60/237,334, attorney docket no. 25791.48, filed on 10/2/2000, (22) U.S. provisional patent application serial no. 60/270,007, attorney docket no. 25791.50, filed on 2/20/2001; (23) U.S. provisional patent application serial no. 60/262,434, attorney docket no. 25791.51, filed on 1/17/2001; (24) U.S. provisional patent application serial no. 60/259,486, attorney docket no. 25791.52, filed on 1/3/2001; (25) U.S. provisional patent application serial no. _____, attorney docket no. 25791.61, filed on 7/6/2001; (26) U.S. provisional patent application serial no. _____, attorney docket no. 25791.59, filed on 8/20/2001; (27) U.S. provisional patent application serial no. _____, attorney docket no. 25791.67, filed on 9/6/2001; and (28) U.S. provisional patent application serial no. _____, attorney docket no. 25791.67.02, filed on 9/10/2001, the disclosures of which are incorporated herein by reference.

[0057] In a preferred embodiment, the ratio of the unexpanded portion of the expandable tubular member 220 to the inside diameter of the work casing 200 ranges from about 8 to 40 %. In this manner, the expandable tubular

member 220 can be easily positioned within and through collapsed sections of the wellbore casing 200.

5 [0058] In a preferred embodiment, the ratio of the inside diameter of the radially expanded tubular member 220 to the inside diameter of the wellbore casing 200 ranges from about 8 to 40 %. In this manner, a large passage is provided within the expanded tubular member 220 for the passage of additional production tools and/or production fluids and gases.

10 [0059] An apparatus has been described that includes one or more primary solid tubulars, n slotted tubulars, n-1 intermediate solid tubulars, and a shoe. Each primary solid tubular includes one or more external annular seals. The slotted tubulars are coupled to the primary solid tubulars. The intermediate solid tubulars are coupled to and interleaved among the slotted tubulars. Each intermediate solid tubular includes one or more external annular seals. The shoe is coupled to one of the slotted tubulars.

15 [0060] A method of isolating a first subterranean zone from a second subterranean zone in a wellbore has been described that includes positioning one or more primary solid tubulars and one or more slotted tubulars within the wellbore. The primary solid tubulars traverse the first subterranean zone and the slotted tubulars traverse the second subterranean zone. The slotted tubulars and the solid tubulars are fluidically coupled. The passage of fluids from the first subterranean zone to the second subterranean zone within the wellbore external to the solid and slotted tubulars is prevented.

20 [0061] A method of extracting materials from a producing subterranean zone in a wellbore, at least a portion of the wellbore including a casing, has been described that includes positioning one or more primary solid tubulars and one or more slotted tubulars within the wellbore. The primary solid tubulars are fluidically coupled with the casing. The slotted tubulars traverse the producing subterranean zone. The producing subterranean zone is fluidically isolated from at least one other subterranean zone within the wellbore. At least one of the slotted tubulars is fluidically coupled with the producing subterranean zone. In a

preferred embodiment, the method further includes controllably fluidically decoupling at least one of the slotted tubulars from at least one other of the slotted tubulars.

5 [0062] An apparatus has also been described that includes one or more solid tubular members, each solid tubular member including one or more external seals, one or more slotted tubular members coupled to the solid tubular members, a shoe coupled to one of the slotted tubular members, and one or more packers positioned within one or more of the tubular members. Each packer includes: a radially expanded tubular member, and one or more sealing members coupled to the outer surface of the radially expanded tubular member. In a preferred embodiment, the apparatus further includes one or more intermediate solid tubular members coupled to and interleaved among the slotted tubular members, each intermediate solid tubular member including one or more external seals. In a preferred embodiment, the apparatus further includes one or more valve members. In a preferred embodiment, one or more of the intermediate solid tubular members include one or more valve members.

10 [0063] An apparatus has also been described that includes one or more primary solid tubulars, each primary solid tubular including one or more external annular seals, n slotted tubulars coupled to the primary solid tubulars, $n-1$ intermediate solid tubulars coupled to and interleaved among the slotted tubulars, each intermediate solid tubular including one or more external annular seals, a shoe coupled to one of the slotted tubulars, and one or more packers positioned within one or more of the tubulars. Each packer includes: a radially expanded tubular member, and one or more sealing members coupled to the outer surface of the radially expanded tubular member.

15 [0064] A method of isolating a first subterranean zone from a second subterranean zone in a wellbore has also been described that includes positioning one or more primary solid tubulars within the wellbore, the primary solid tubulars traversing the first subterranean zone, positioning one or more slotted tubulars within the wellbore, the slotted tubulars traversing the second

subterranean zone, fluidicly coupling the slotted tubulars and the solid tubulars, preventing the passage of fluids from the first subterranean zone to the second subterranean zone within the wellbore external to the solid and slotted tubulars, and fluidicly isolating one or more annular regions within one or more of the tubulars by the process of: positioning an expandable tubular member having one or more sealing members within the tubular, and radially expanding the expandable tubular member.

[0065] A method of extracting materials from a producing subterranean zone in a wellbore, at least a portion of the wellbore including a casing, has also been described that includes positioning one or more primary solid tubulars within the wellbore, fluidicly coupling the primary solid tubulars with the casing, positioning one or more slotted tubulars within the wellbore, the slotted tubulars traversing the producing subterranean zone, fluidicly coupling the slotted tubulars with the solid tubulars, fluidicly isolating the producing subterranean zone from at least one other subterranean zone within the wellbore, fluidicly coupling at least one of the slotted tubulars with the producing subterranean zone, and fluidicly isolating one or more annular regions within one or more of the tubulars by the process of: positioning an expandable tubular member having one or more sealing members within the tubular, and radially expanding the expandable tubular member. In a preferred embodiment, the method further includes controllably fluidicly decoupling at least one of the slotted tubulars from at least one other of the slotted tubulars.

[0066] An apparatus for fluidicly isolating annular sections within a wellbore casing has also been described that includes an expandable tubular member adapted to be positioned within the wellbore casing, one or more sealing members coupled to an outside surface of the expandable tubular member, and an expansion cone movably coupled to the expandable tubular member adapted to radially expand the expandable tubular member.

[0067] A method of fluidicly isolating annular sections within a wellbore casing has also been described that includes positioning an expandable tubular

member having one or more outer sealing members and an expansion cone within the wellbore casing, and axially displacing the expansion cone relative to the expandable tubular member.

5 [0068] A method of fluidically isolating an annular section of a wellbore casing including a collapsed section has also been described that includes positioning an expandable tubular member having one or more outer sealing members and an expansion cone within the wellbore casing, moving at least a portion of the expandable tubular member through the collapsed section of the wellbore casing, and axially displacing the expansion cone relative to the
10 expandable tubular member.

[0069] A packer for sealing an annular region between the packer and a wellbore casing has also been described that includes a radially expanded tubular member and one or more sealing members coupled to the outer surface of the radially expanded tubular member for sealing the annular region between
15 the radially expanded tubular member and the wellbore casing.

[0070] A method of operating a packer comprising an expandable tubular member and an annular sealing member coupled to the exterior of the expandable tubular member has also been provided that includes positioning the packer within a subterranean borehole, and radially expanding the expandable
20 tubular member using an expansion cone.

[0071] Although illustrative embodiments of the invention have been shown and described, a wide range of modification, changes and substitution is contemplated in the foregoing disclosure. In some instances, some features of the present invention may be employed without a corresponding use of the other
25 features. Accordingly, it is appropriate that the appended claims be construed broadly and in a manner consistent with the scope of the invention.

Claims

What is claimed is:

1. An apparatus, comprising:
 - one or more solid tubular members, each solid tubular member including one or more external seals;
 - one or more slotted tubular members coupled to the solid tubular members;
 - a shoe coupled to one of the slotted tubular members; and
 - one or more packers positioned within one or more of the tubular members, each packer including:
 - a radially expanded tubular member; and
 - one or more sealing members coupled to the outer surface of the radially expanded tubular member.
2. The apparatus of claim 1, further comprising:
 - one or more intermediate solid tubular members coupled to and interleaved among the slotted tubular members, each intermediate solid tubular member including one or more external seals.
3. The apparatus of claim 1, further comprising one or more valve members.
4. The apparatus of claim 2, wherein one or more of the intermediate solid tubular members include one or more valve members.
5. An apparatus, comprising:
 - one or more primary solid tubulars, each primary solid tubular including one or more external annular seals;
 - n slotted tubulars coupled to the primary solid tubulars;

n-1 intermediate solid tubulars coupled to and interleaved among the slotted tubulars, each intermediate solid tubular including one or more external annular seals;
a shoe coupled to one of the slotted tubulars; and
one or more packers positioned within one or more of the tubulars, each packer including:
a radially expanded tubular member; and
one or more sealing members coupled to the outer surface of the radially expanded tubular member.

6. A method of isolating a first subterranean zone from a second subterranean zone in a wellbore, comprising:
positioning one or more primary solid tubulars within the wellbore, the primary solid tubulars traversing the first subterranean zone;
positioning one or more slotted tubulars within the wellbore, the slotted tubulars traversing the second subterranean zone;
fluidicly coupling the slotted tubulars and the solid tubulars;
preventing the passage of fluids from the first subterranean zone to the second subterranean zone within the wellbore external to the solid and slotted tubulars; and
fluidicly isolating one or more annular regions within one or more of the tubulars by the process of:
positioning an expandable tubular member having one or more sealing members within the tubular; and
radially expanding the expandable tubular member.

7. A method of extracting materials from a producing subterranean zone in a wellbore, at least a portion of the wellbore including a casing, comprising:
positioning one or more primary solid tubulars within the wellbore;
fluidicly coupling the primary solid tubulars with the casing;

positioning one or more slotted tubulars within the wellbore, the slotted tubulars traversing the producing subterranean zone;
fluidicly coupling the slotted tubulars with the solid tubulars;
fluidicly isolating the producing subterranean zone from at least one other subterranean zone within the wellbore;
fluidicly coupling at least one of the slotted tubulars with the producing subterranean zone; and
fluidicly isolating one or more annular regions within one or more of the tubulars by the process of:
 positioning an expandable tubular member having one or more sealing members within the tubular; and
 radially expanding the expandable tubular member.

8. The method of claim 7, further comprising:
 controllably fluidicly decoupling at least one of the slotted tubulars from at least one other of the slotted tubulars.
9. An apparatus for fluidicly isolating annular sections within a wellbore casing, comprising:
 an expandable tubular member adapted to be positioned within the wellbore casing;
 one or more sealing members coupled to an outside surface of the expandable tubular member; and
 an expansion cone movably coupled to the expandable tubular member adapted to radially expand the expandable tubular member.
10. A method of fluidicly isolating annular sections within a wellbore casing, comprising:

positioning an expandable tubular member having one or more outer sealing members and an expansion cone within the wellbore casing; and
axially displacing the expansion cone relative to the expandable tubular member.

11. A method of fluidically isolating an annular section of a wellbore casing including a collapsed section, comprising:

positioning an expandable tubular member having one or more outer sealing members and an expansion cone within the wellbore casing;
moving at least a portion of the expandable tubular member through the collapsed section of the wellbore casing; and
axially displacing the expansion cone relative to the expandable tubular member.

12. A packer for sealing an annular region between the packer and a wellbore casing, comprising:

a radially expanded tubular member; and
one or more sealing members coupled to the outer surface of the radially expanded tubular member for sealing the annular region between the radially expanded tubular member and the wellbore casing.

13. A method of operating a packer comprising an expandable tubular member and an annular sealing member coupled to the exterior of the expandable tubular member, comprising:

positioning the packer within a subterranean borehole; and
radially expanding the expandable tubular member using an expansion cone.



INVESTOR IN PEOPLE

Application No: GB 0219757.2
Claims searched: 9 to 13

Examiner: Richard So
Date of search: 20 January 2003

Patents Act 1977 : Search Report under Section 17

Documents considered to be relevant:

Category	Relevant to claims	Identity of document and passage or figure of particular relevance
X	9 to 11.	GB 2344606 A (SHELL). See whole document in particular figures 2 to 4 and page 10 line 16 to page 11 line 14.
X	9, 12 and 13.	EP 1152120 A (HALLIBURTON ENERGY SERVICES INC.). See whole document in particular figures 1a and 1b and paragraphs 0049 and 0055.
&	-	US 2002/0066576 A1 (COOK et al.). See whole document in particular figures 2a to 2c and paragraphs 0004, 0005, 0011, 0017, 0018, 0026, 0040, and 0047.

Categories:

X	Document indicating lack of novelty or inventive step	A	Document indicating technological background and/or state of the art.
Y	Document indicating lack of inventive step if combined with one or more other documents of same category.	P	Document published on or after the declared priority date but before the filing date of this invention.
&	Member of the same patent family	E	Patent document published on or after, but with priority date earlier than, the filing date of this application.

Field of Search:

Search of GB, EP, WO & US patent documents classified in the following areas of the UKC^v:

E1F.

Worldwide search of patent documents classified in the following areas of the IPC⁷:

E21B.

The following online and other databases have been used in the preparation of this search report :

Online: EPODOC, JAPIO, WPI, TXTEP, TXTGB, TXTUS, TXTWO.



INVESTOR IN PEOPLE

Application No: GB 0219757.2
Claims searched: 1 to 7

Examiner: Richard So
Date of search: 25 November 2002

**Patents Act 1977
Search Report under Section 17**

Databases searched:

UK Patent Office collections, including GB, EP, WO & US patent specifications, in:
UK CI (Ed.T): EIF (FLA, FMU, FLW)
Int CI (Ed.7): E21B (29/00, 43/10, 43/12, 43/14, 43/16).
Other: Online: EPODOC, JAPIO, WPI, TXTEP, TXTGB, TXTUS, TXTWO.

Documents considered to be relevant:

Category	Identity of document and relevant passage	Relevant to claims
A, P	GB 2370301 A (BAKER HUGHES INC.). See whole document in particular figures 1a to 5b and 11 to 19, page 7 lines 1 to 21, and page 51 line 21 to page 16 line 20.	-
A	GB 2343691 A (SHELL). See whole document especially figures 1 to 2d.	-
A, P	US 2002/0148612 (COOK et al.). See whole document especially the figures	-
&	US 2002/0066576 (COOK et al.). See whole document especially the figures	-

X	Document indicating lack of novelty or inventive step	A	Document indicating technological background and/or state of the art.
Y	Document indicating lack of inventive step if combined with one or more other documents of same category.	P	Document published on or after the declared priority date but before the filing date of this invention.
&	Member of the same patent family	E	Patent document published on or after, but with priority date earlier than, the filing date of this application.